

ScientificAir™
by SteriLumen

Engineering Air
for a Cleaner
Environment



ScientificAir™
by SteriLumen

Available through:

Chemex Industries, Inc.

3 Chattanooga, Irvine, CA 92620

714-832-8441

866-938-7657

Scientific Air's S400 goes beyond filtration -- capturing airborne pathogens with a UVC dosage close and long enough for up to a **99.9995%** virus kill rate, eliminating bacteria, mold, odor, and VOCs.

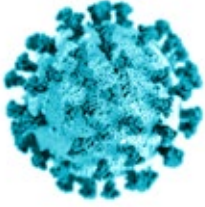

Virus



Bacteria

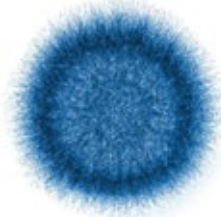

Mold



Odor VOCs



DISINFECT AIR -- FAST!

The S400 uses patented **UVC technology**, bio-aerosol full room size laboratory validated, to kill pathogens, reduce particulates, removes mold, odor, and VOCs.

Helps reduce airborne HAI's with up to a 99.9995% UVC pathogen killing rate.

Reduces airborne particulates by as much as 99.97%.

Quiet 24/7 UVC air scrubbing, entirely safe for patients and staff.

Hospital proven in facilities like:

- NYU Medical Center
- University of Rochester
- Federal VA Hospitals
- NY Health+Hospitals
- Baptist Health Systems

Powerful air management **24/7 in occupied spaces** like emergency rooms, isolation rooms, patient rooms, compounding pharmacies, laboratories, food-service, waiting areas, and more.

Room size bio-aerosol laboratory tested

The S400 conducted two separate efficacy analysis at independent nationally recognized facilities; Microchem Laboratories and Environmental Diagnostics Laboratories. Tests were conducted in a 10'x 10'x 8' bio-aerosol guideline aerosolized chambers.



Test Device	Microorganism	Inoculum Concentration (CFU/ml)	Treatment Time Point	Recovery (CFU/m ³)	Percent Reduction Vs. Time Zero	Log ₁₀ Reduction Vs. Time Zero		
Scientific Air Management S400	MS2 Bacteriophage ATCC 15597-B1	1.00E+07	Time Zero	1.00E+06	N/A	2.00		
			5 minutes	1.00E+04			99.0%	4.00
			15 minutes	1.00E+02			99.990%	5.30
			30 minutes	5.00E+00			99.9995%	



S400 Features

- High volume 400 cubic feet per minute fan operation for complete air change within 2 -5 minutes in a typical room of 800 cubic feet.
- Powerful yet quiet brush-less high-speed motor disinfects High Volumes of air with 42 - 46 decibels at average operating speeds.
- High capacity HEPA pre-filter cartridge captures particulates down to 0.3 microns.
- Large volume UVC induction chamber for full process of pathogen-laden air, lab tested for up to 99.9995% efficacy.
- 360-degree total air intake system creates a quiet undetectable air induction vortex.
- Patented carbon substrate for complete odor and VOC removal.
- No airflow disturbance, no temperature or humidity variations, and no negative or positive air pressure interference.
- Zero ozone production.
- 120 voltage standard outlet --same power requirements as a typical residential ceiling fan.
- On-Board Digital screen reporting
- HEPA Filter/Air Flow integrity metering
- UVC Light integrity/intensity metering

- Carbon Final Filtration metering
- Pathogen and Particulate process metering
- Premium hospital wheels for effortless mobility on all surfaces with toe touch locking wheels.
- Filter replacements available with simple economical annual self service.

Eliminates up to **99.9995%** of airborne viruses in minutes!

37" height
22" wide
72 lbs.



Chemex Industries, Inc.

www.chemexindustries.com ▪ Phone: 714-832-8441 ▪ 866-938-7657

S400 Specification sheet

The S400 uses patented UVC technology, laboratory tested in bio-aerosol test chambers, to eliminate up to 99.9995% of viruses, eradicate bacteria and mold, removing up to 97% of non-viable particulates, destroying odor, and removing VOCs in a standard room in minutes!

The S400 is facility proven. Nationally recognized by hospitals like NYU Medical Center, University of Rochester, Federal VA Hospitals, NY Health+Hospitals, and Baptist Health Systems. The S400 is effective in emergency rooms, isolation rooms, patient rooms, compounding pharmacies, laboratories, food-service, waiting areas, and more.

SPECIFICATIONS

Physical Dimensions

- 22 x 37
- Weighs 72 pounds

Electrical Ratings

- Rated at 120 volts
- Rated at 1.6 Amps
- Green Dot Grounded

Decibel Level

- 62-64 decibels Certifications
- MET US/C UL 507

Construction

- High grade steel
- Antimicrobial powder coating
- Aluminum wheel base

Air Circulation

- 400 CFM Motor Fan Speed
- Will not affect positive/negative pressure
- Air intake matches air exhaust
- 360 degree vortex air flow over a large surface area.
- Will not affect room air exchanges or room air flow.

Disinfection Process

- HEPA (0.3 um) pre-filter
- UVC 253.7nm (254 nm) 48W non-ozone light array
- Treated carbon-coir substrate final filter granulated moisture resistant

Cleaning

- Wipe down entire machine with antibiotic cleaner

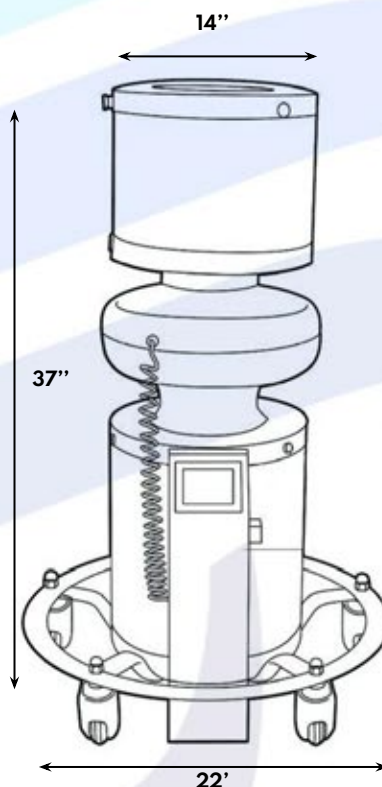

FEATURES

- Powerful 400 CFM fan performs complete air change disinfection within a few minutes in a typical room of 800 cubic feet (10'x10'x 8')
- High-capacity HEPA pre-filter reduces particulates down to 0.3 microns.
- Large-volume UVC kill chamber processing germ-laden air destroying virus, bacteria, Mold, odor, and VOCs.
- 360-degree total air circulation system is quiet, and undetectable with matching air induction and exhaust vortex.
- Zero airflow disturbance, no temperature or humidity variations, no negative or positive air pressure interference, NO by products, NO ozone.
- Lightweight 72 lbs. With aluminum balanced security base for superb stability and safety.
- 120 voltage standard outlet with the same power requirements as a typical residential ceiling fan.
- Green-Dot grounded electrical cord.
- On-Board Digital screen reporting:
 - HEPA filter/air flow integrity
 - Carbon final filtration integrity
 - UVC light intensity/integrity
 - Processed CFM air volume
- Premium hospital wheel for effortless mobility on all surfaces with touch toe locking casters.
- Consumable component "snap-in snap-out" replacements with simple and economical annual self service.
- Dimensions 22"W x 37"H 72lbs.

ScientificAir™
by Sterilumen

Available through:
Chemex Industries, Inc.
3 Chattanooga, Irvine, CA 92620
714-832-8441
866-938-7657

